

DIMENSIONS AND NOMINAL VALUES

	Volum. del.	Depth of immer.	Pipe conn.	Weight	Power	Voltage	Fre- quency	Rated current	Revo- lution
TYPE	l/min	h(mm)	G	kg	kw	V(Δ/Y)	Hz	A	rpm
CP 12	100	130	G 3/4	6.6	0.37	230/400	50	1.9/1.1	2820
CP 17		180		7.1					
CP 22		230		7.4					
CP 27		280		7.9					

Volumetric delivery * is measured at 2m water height. (+ % 10)

Performance Curve

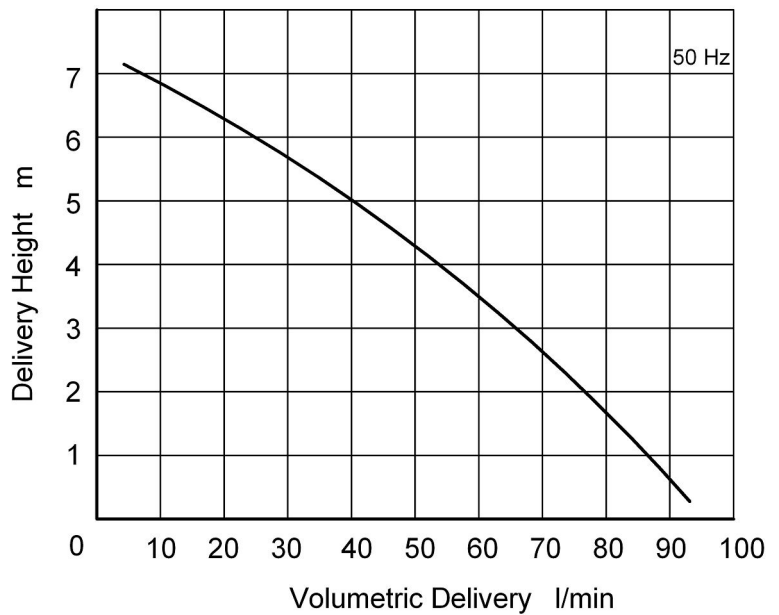

Kinematic viscosity: 90mm²/s²

Operating Temperature Range: 0...+60 °C

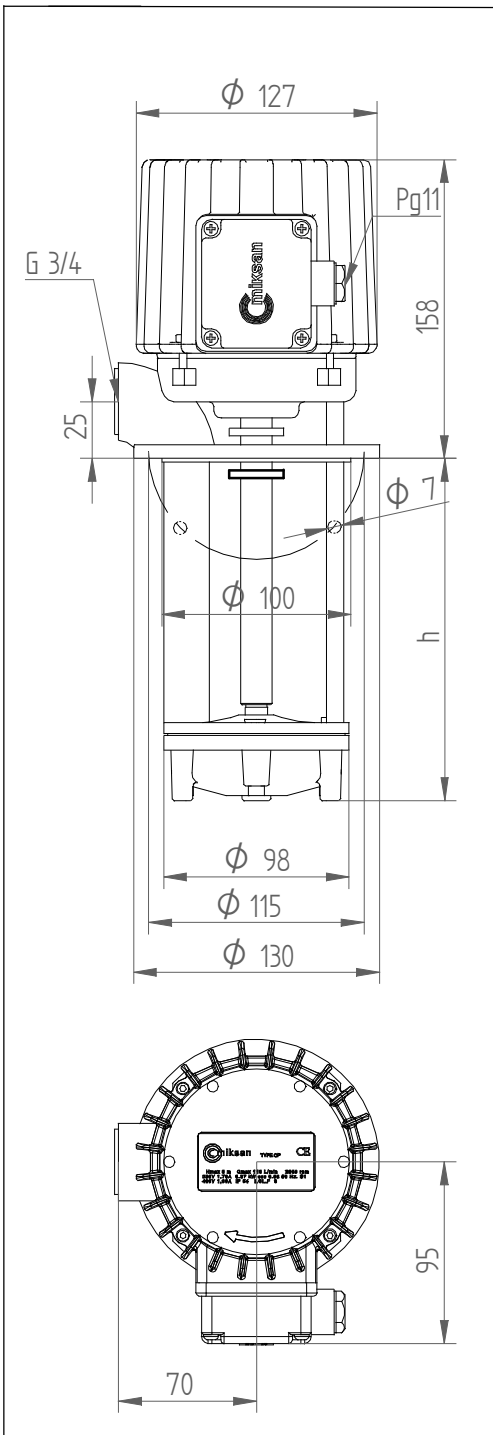

PROPERTIES:

- CP Pump series are designed for circulation of cutting and chemical fluids.
- They serve as cooling and lubrication units on machine tools and automatic sews, etc.
- The shaft of the CP Pump is made of engineering steel.
- The main body of standart CP Pump is cast iron.
- The impeller and pump intake cover of standart CP Pump are plastic. On demand , the impeller can be brass and, the pump intake cover can be cost iron.
- Standard CP Pump has a three-phase motor . On demand, it can be equipped with a single-phase motor.

THE DIMENSIONS OF THE PUMPS CONFORMS TO STANDARD EN 12157 SPECIFICATIONS.